



Digital Twin – revolutionizes development

modelling before manufacturing



RAHUL VERMA
BUSINESS DEVELOPMENT
B&R INDUSTRIAL AUTOMATION PVT LTD

Requirements for the development process

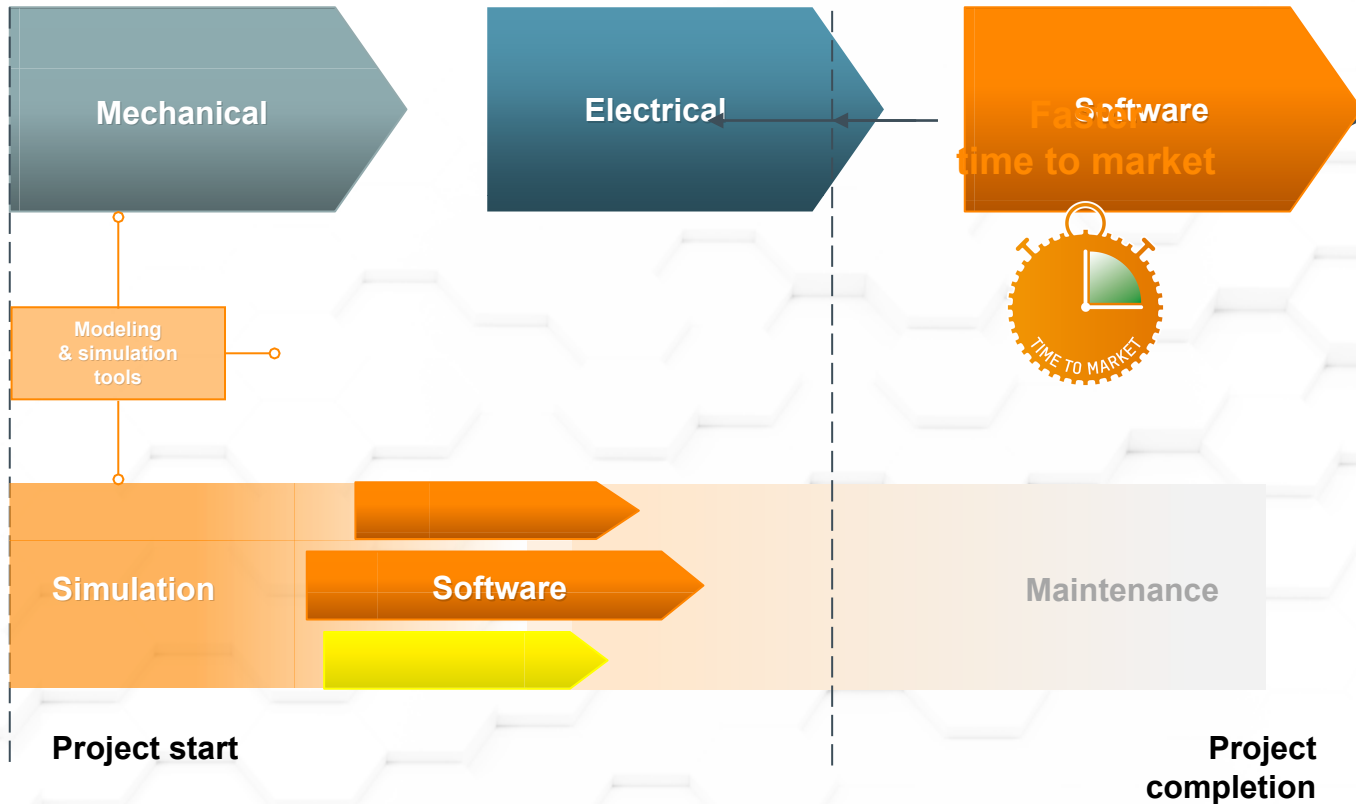

Why do we need digital twins?



Simulation & Digital Twin

Shorter TTM

Accelerated development and testing

Better ROI

Reduced development costs

Reduced dependency on expensive, time-consuming prototyping

Higher OEE

Live testing of changes and updates

Configuration without stopping machine

Easy maintenance

Easy troubleshooting, repair and maintenance (without training)

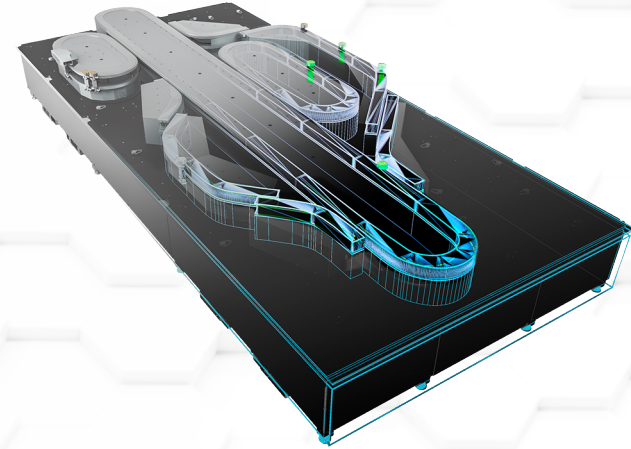



Virtual commissioning

Digital twins

Simulation



Visualization early in design phase

Optimal sizing and layout

Software and function testing



Animation

Visualization early in design phase

Collision avoidance

Optimal sizing and layout

Physics, dynamics

Software and function testing

Software testing

Function testing

Migrating to real machine

Challenges in software development

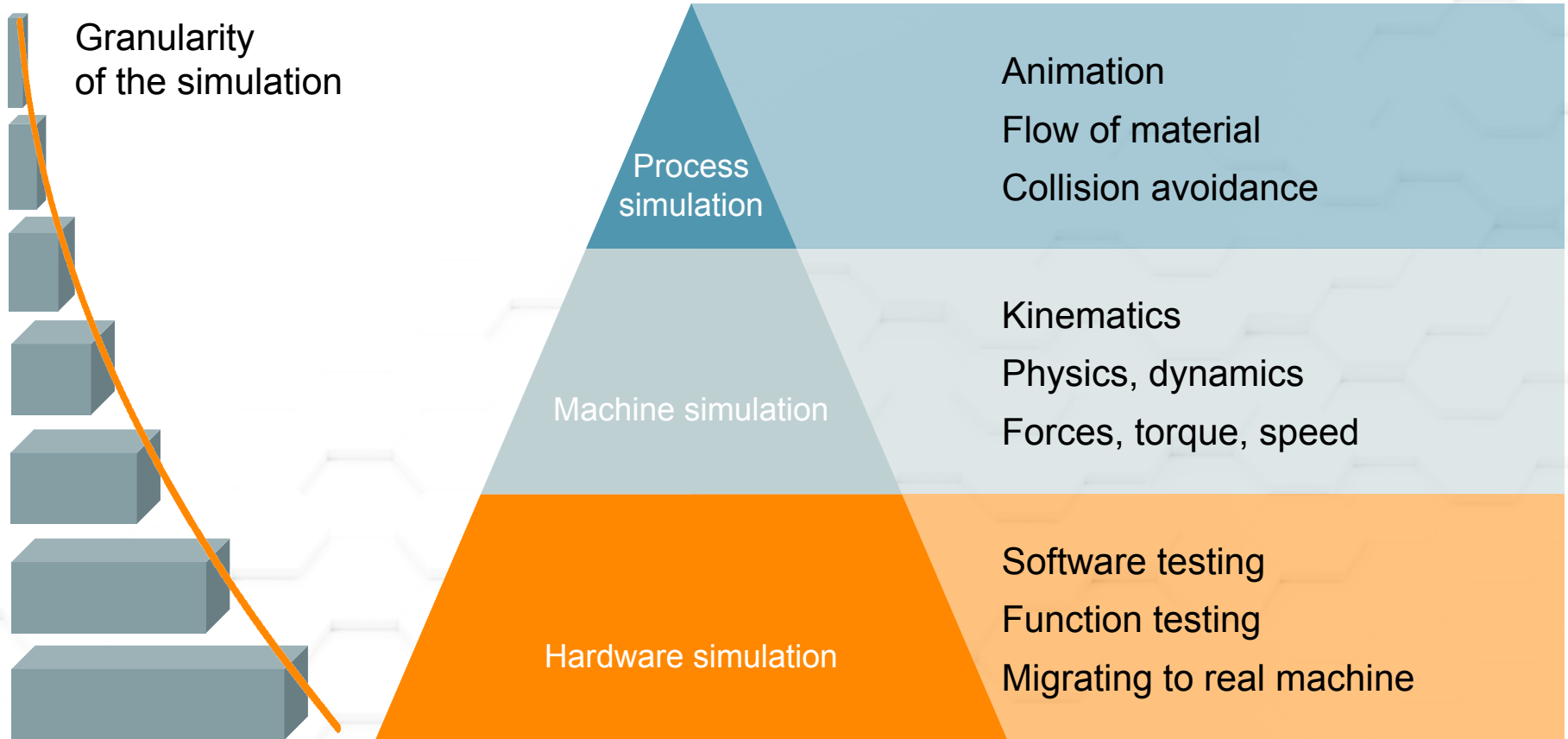



Line and process simulation
industrialPhysics B&R Edition



Simulation models
Directly from CAD



Connect controllers

Synchronized
engineering

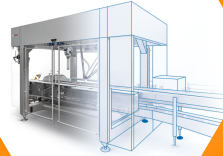

Virtual commissioning of
sequential controls up to
robotics controls



Consistent process
along entire value chain



Transfer models
to VR and AR glasses

Model-based development with industrialPhysics

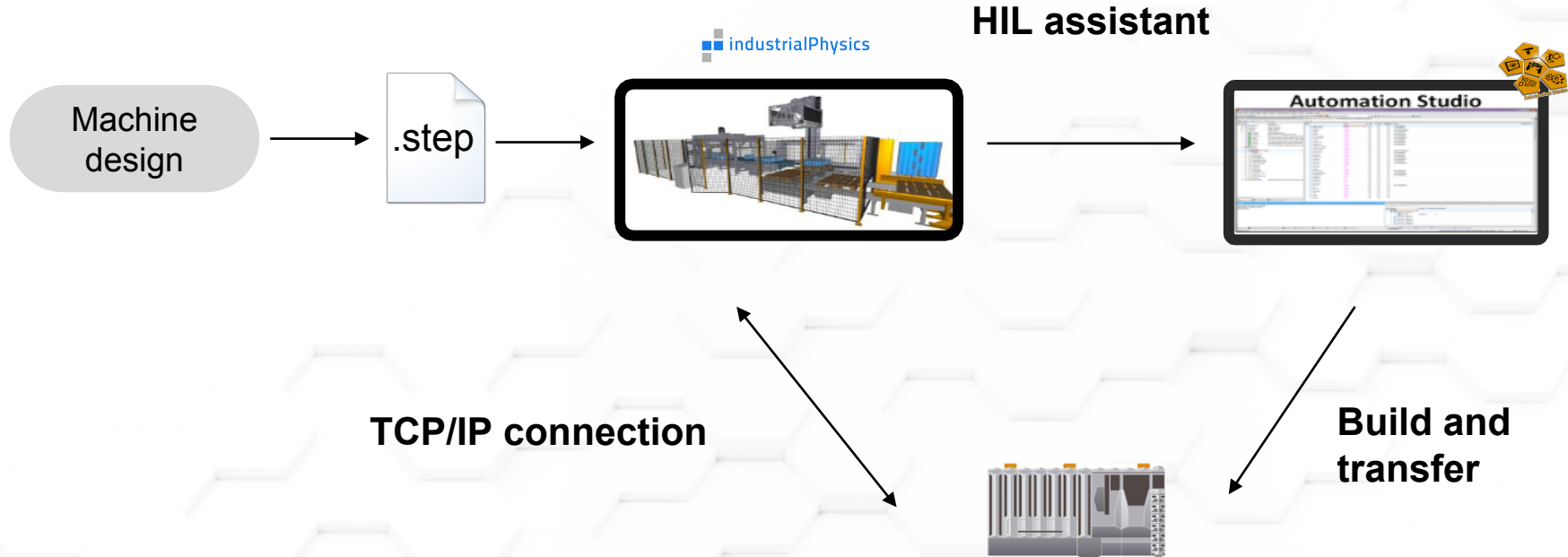



Usage example

Pharmaceutical industry

Use case – Pharmaceutical industry



Goal

- Accelerate development of machine software
- Shorten commissioning time

Specification

- 5 months to machine presentation

Solution

- Use a digital twin

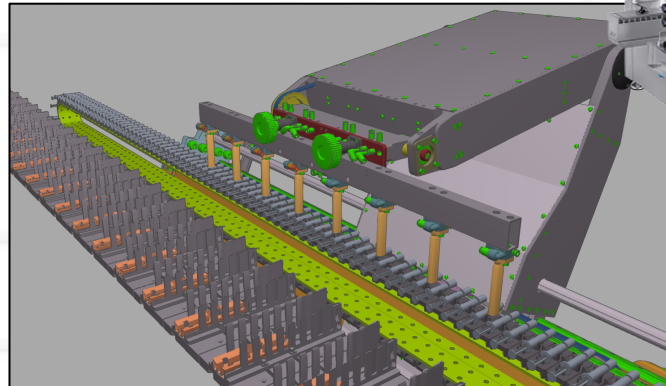



Results

Virtual machine

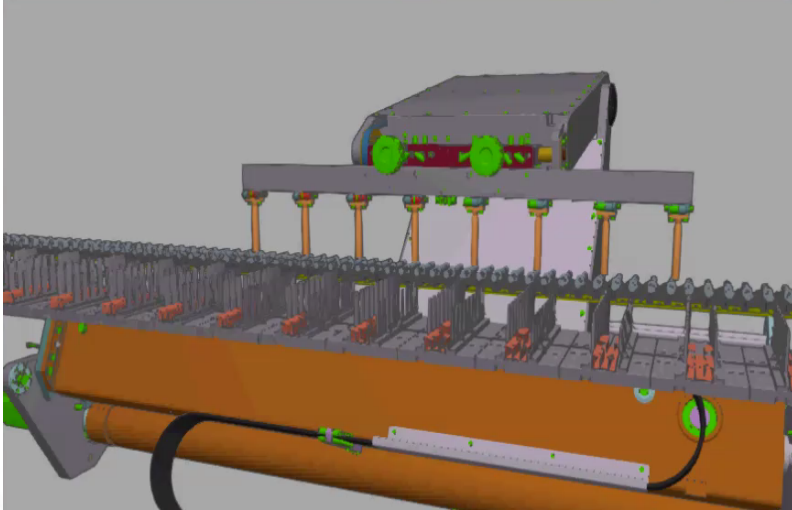

Real machine

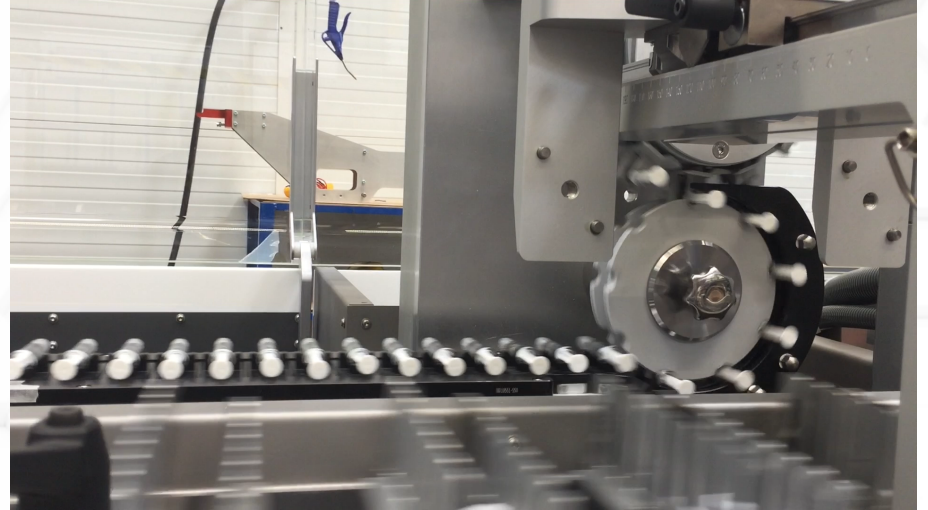



Virtual reality with industrialPhysics B&R Edition

Potential applications of virtual reality



Development of
equipment and products



Basis for design
concepts



Training and
instructions

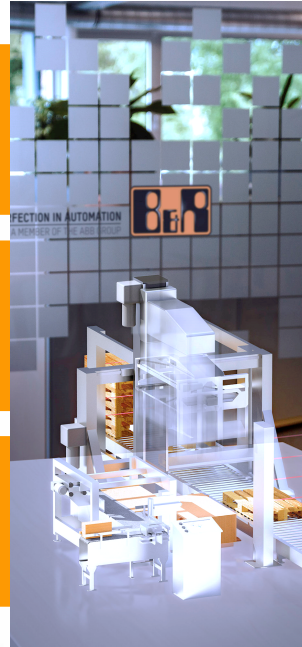

Ergonomic evaluations



Show live data in model



Factory and layout
planning



Example of virtual reality



Position in virtual reality

Defined starting point in industrialPhysics

Navigation

Position of VR headset

Forward motion using HTC Vive

Interaction

HTC Vive controller

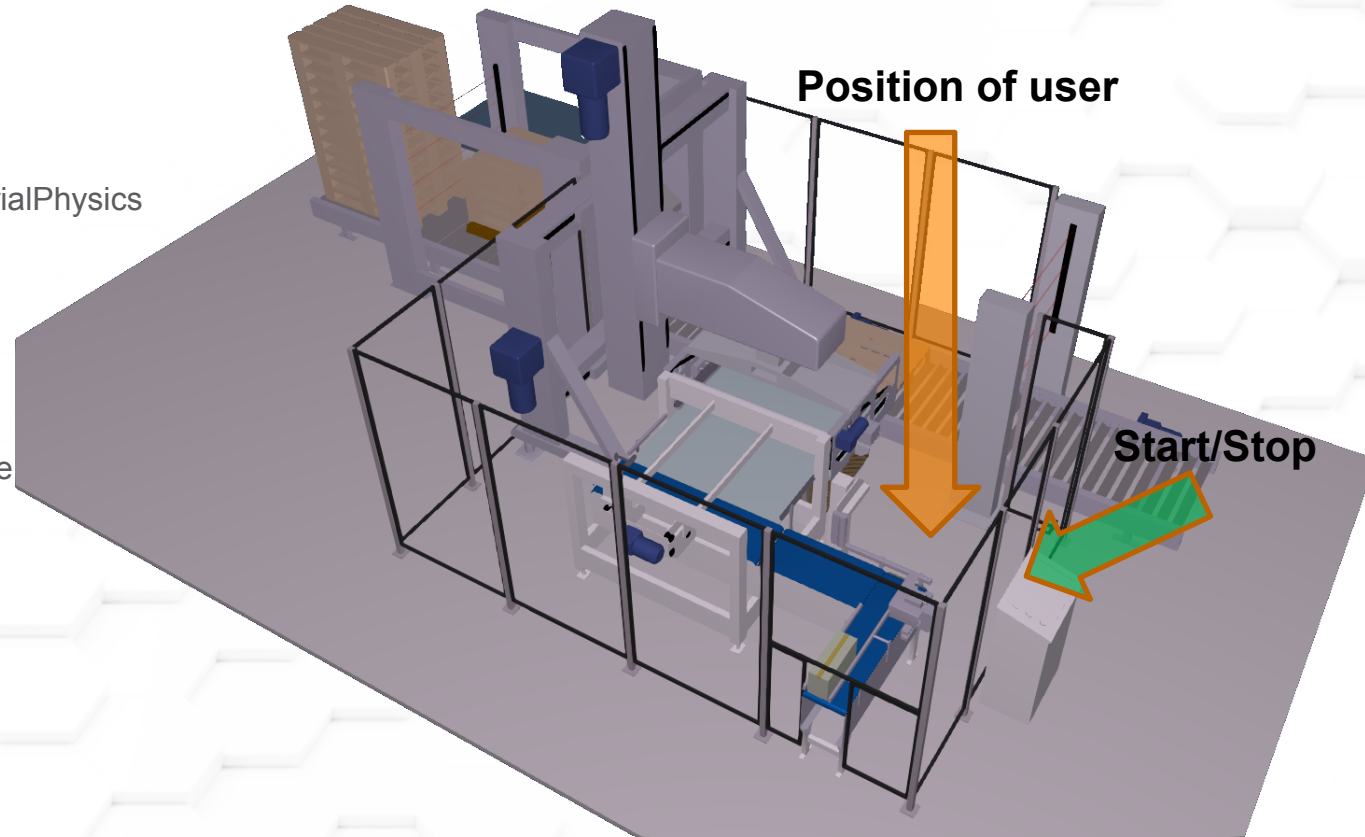

Virtual reality demo

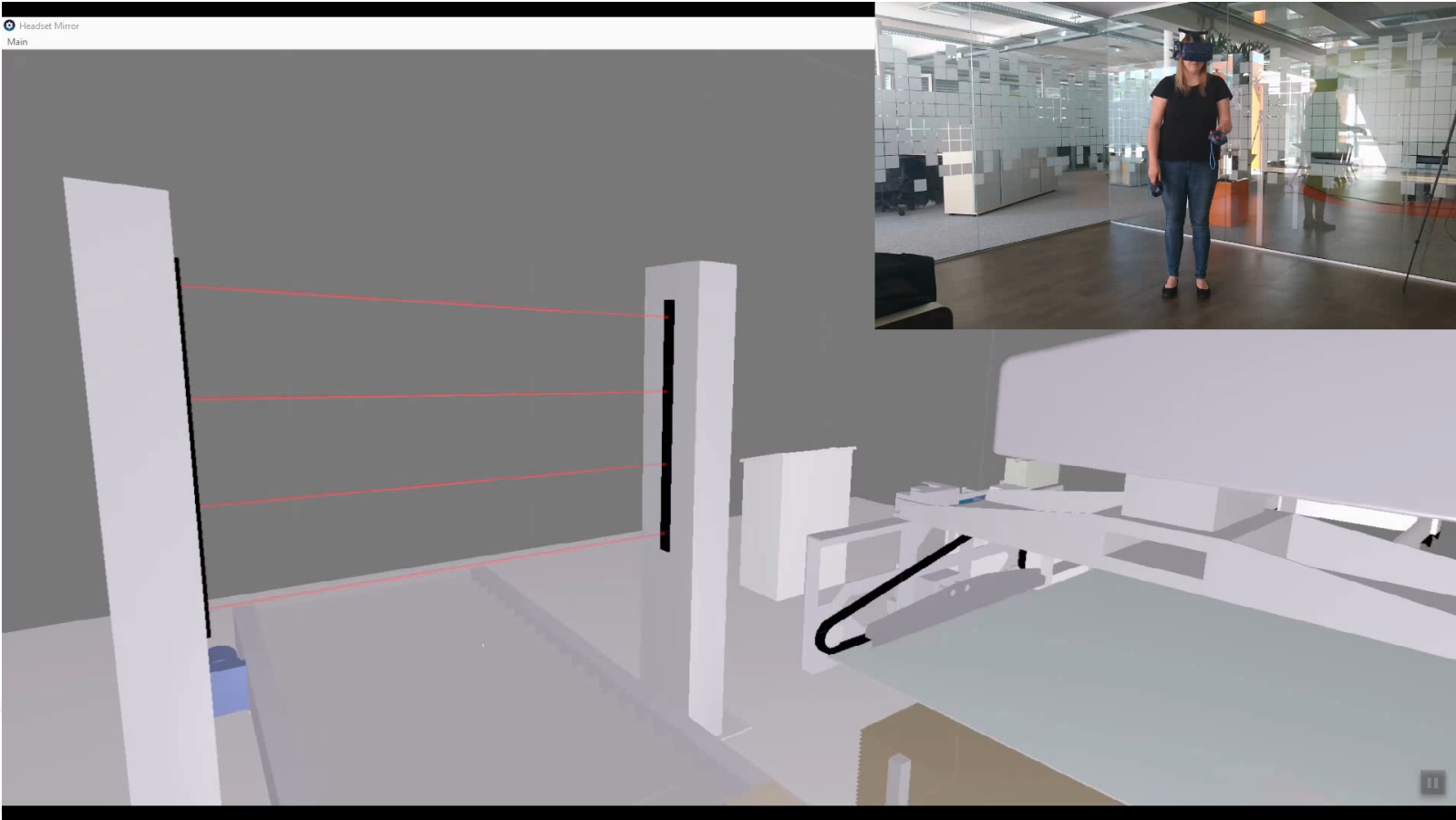

Challenges in software development

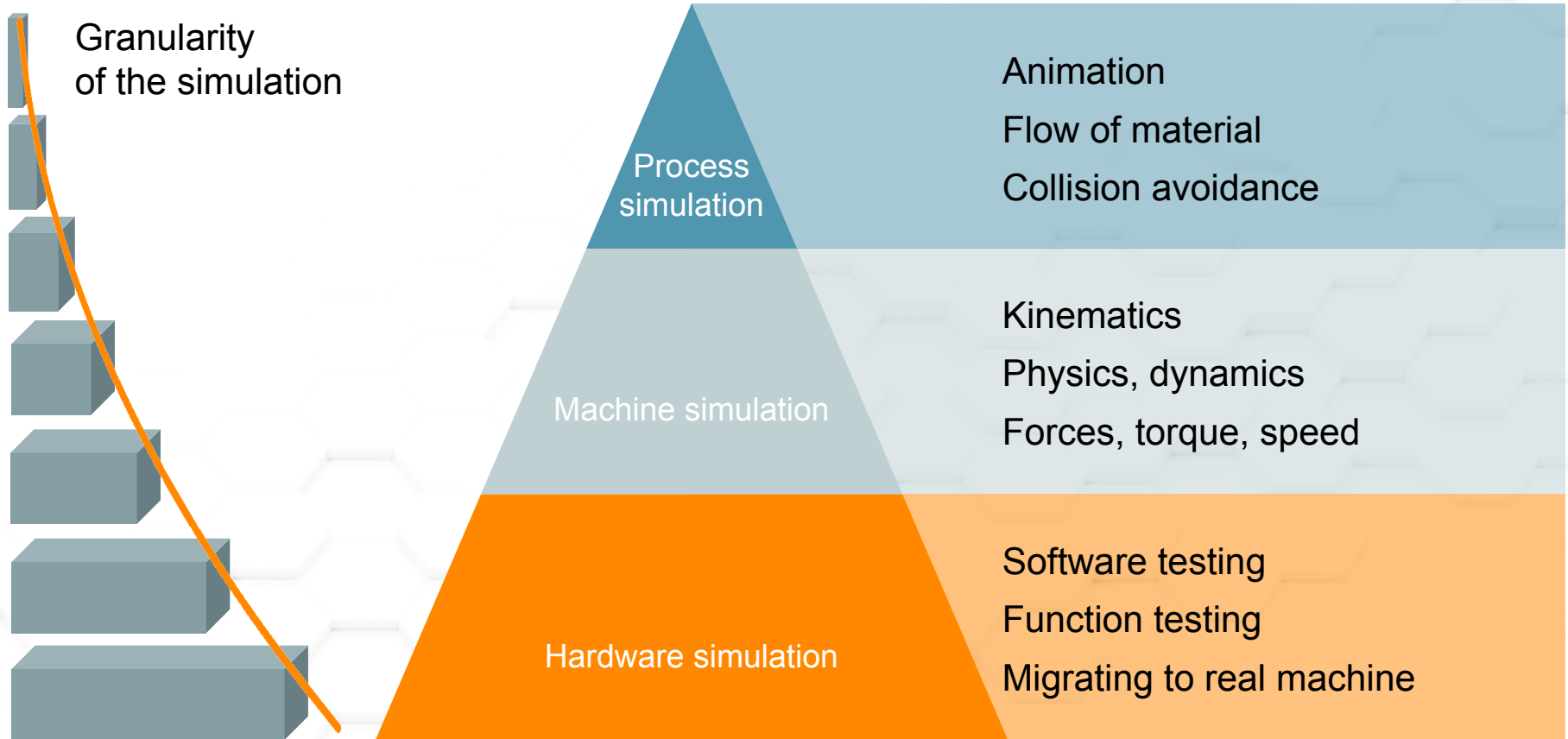



Simulating machines and components
B&R MapleSim Connector



Simulation models
from CRM



Generate real time
models automatically



Synchronized
engineering



Create models easily
with Modelica



Motor design parameters



Transfer models
to Scene Viewer

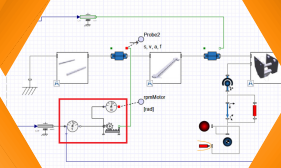

Develop models faster and error-free

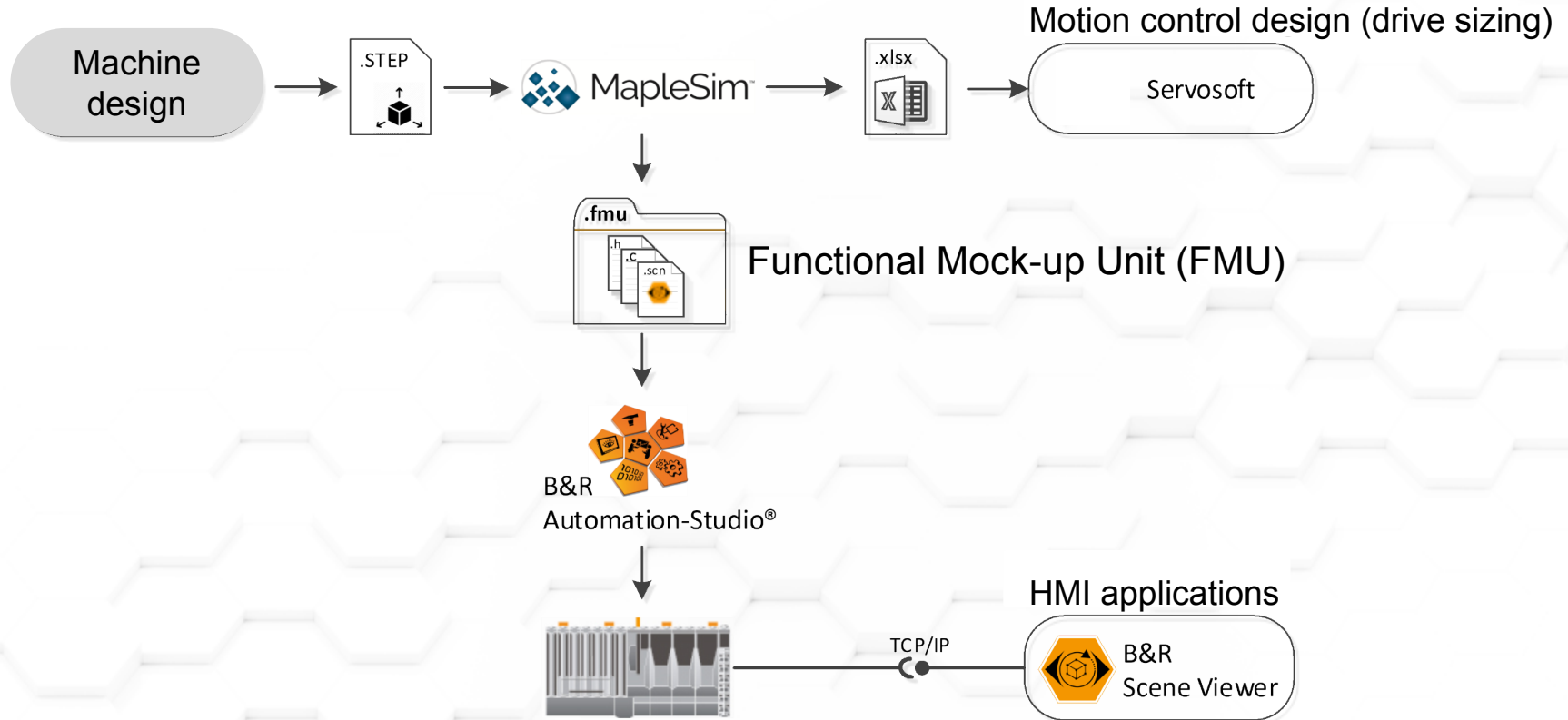

Example of workflow

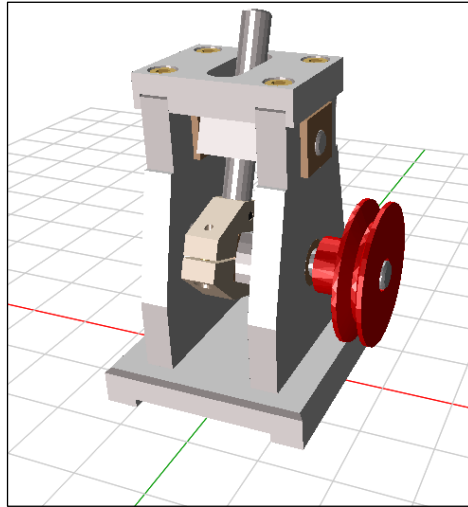

Motion control design (drive sizing)

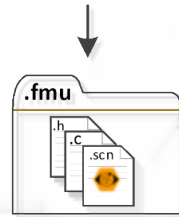
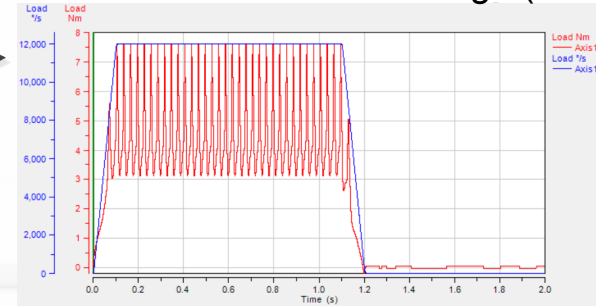

B&R
Automation-Studio®

No
Image



HMI applications

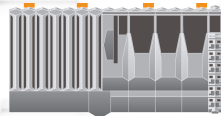
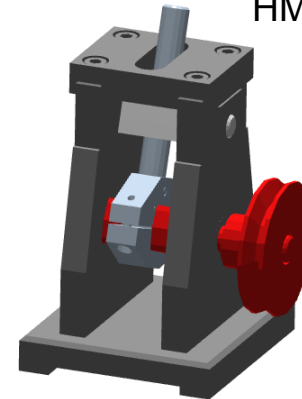

Goals of B&R MapleSim Connector



Size machine components precisely

Validate controls strategy

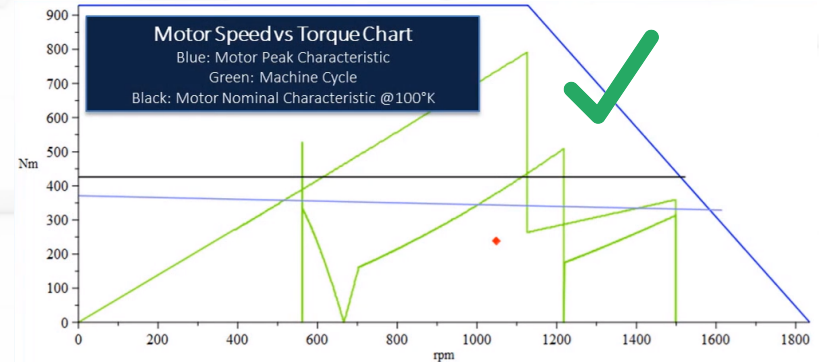
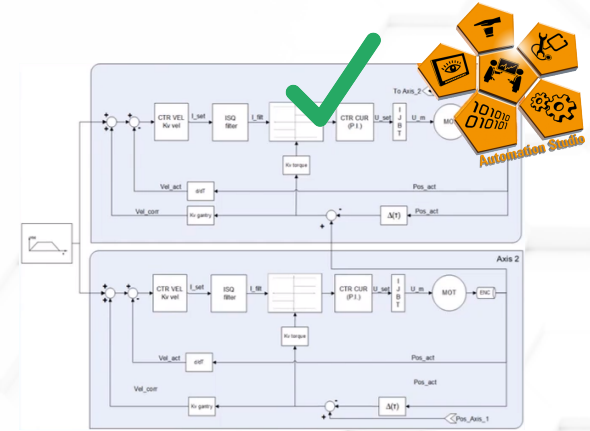
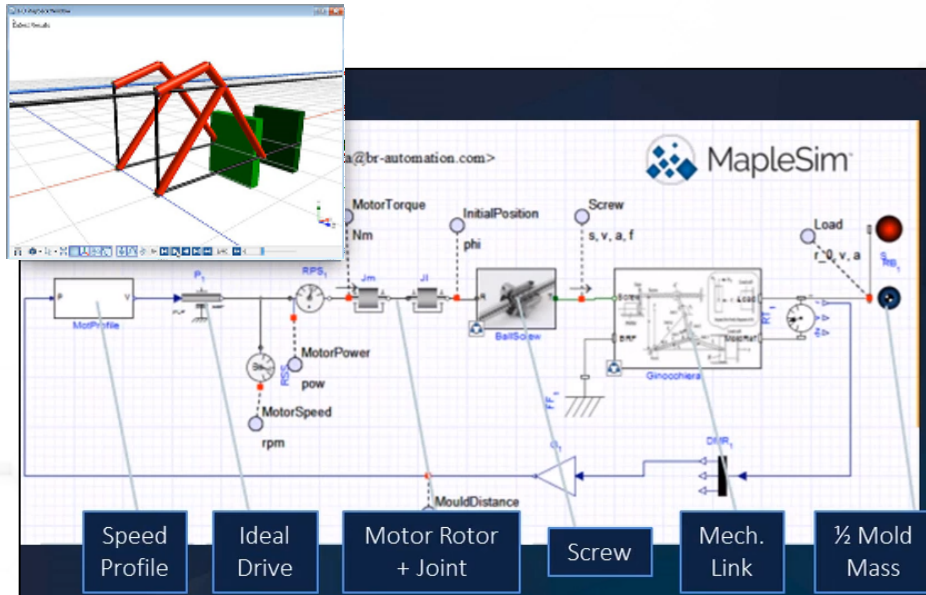

Challenges in software development



Managing increasingly complex systems ✓



Shortening commissioning times ✓



Facilitating innovation ✓



Optimizing internal processes ✓



Reaching physical limits ✓



New ways to influence processes ✓



PERFECTION IN AUTOMATION

